

G100 Surface-Mounted Corner Guards consist of a formidable 50.8mm vinyl and 6.35mm radius cover mounted over a continuous retainer. Corner Guards are an attractive and durable solution to unsightly, damaged corners. G100 Mounted Corner Guards provide support in medium-to high-impact areas.

For more information on Corner Guards please get in touch with Materialised.

G100 Corner Guards - 50.8mm wings

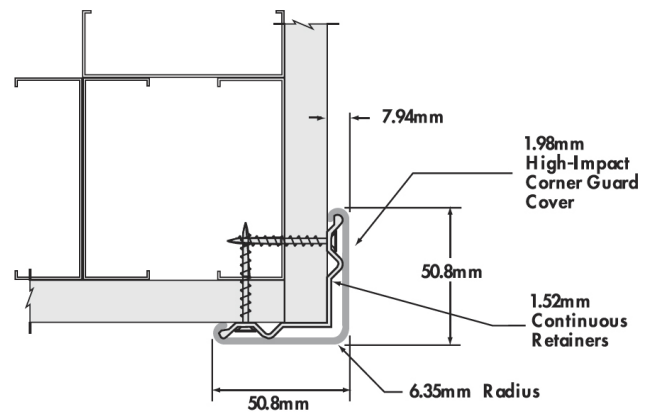

G101 Corner Guard Standard End Cap

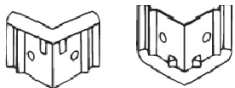

Top Cap Bottom Cap

Please note that at least one G101 Standard end cap is needed per corner.

INSTALLATION INSTRUCTIONS

G100 & G101 SURFACE MOUNTED CORNER GUARDS & CAPS

Surface Mounted Corner Guard

1. Apply and secure a bottom cap beginning directly above cove base with appropriate fasteners.
2. Apply continuous retainer to wall directly above bottom cap with appropriate fasteners at 457.2mm O.C.
3. Install top cap directly above aluminium retainer with appropriate fasteners.
4. Snap precut Corner Guard cover in position. Cover should be lipped over one edge and pressure applied towards opposite leg from centre with a "snap action" movement. Procedure should begin at bottom and be repeated as necessary for full height of cover.

If needing to cut the corner guards then you can use a chop or mitre saw. We recommend using a fine-tooth carbide tip blade.

Date: March 2023

